

# IM3523, IM3533, IM3533-01 LCR Testers

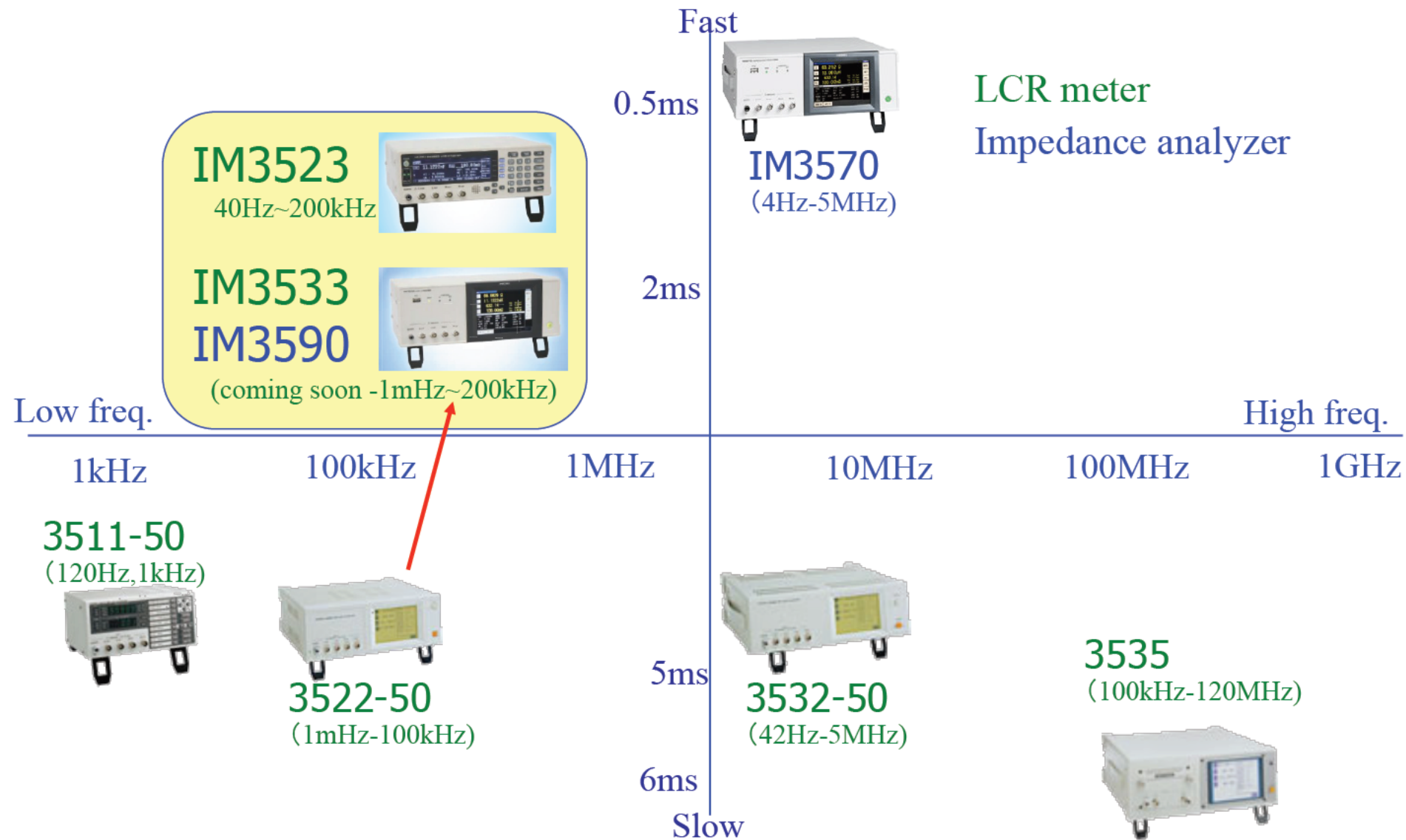

HIOKI E. E. CORPORATION

# Product Line Up



# Main Features

1. Simple Operation
2. Increase test quantity = Fast measurement
3. Accurate and reliable measurement
4. Compact design

IM3523: Simple use for production lines

IM3533: Transformer parameters

IM3533-01: Sweep function



# Easy Operation (IM3523)

- 10-key pad for inputting limit values
- Range is automatically set according to the limit values
- Measurement conditions are independently set to each range

Keys for basic operation is available on the front panel

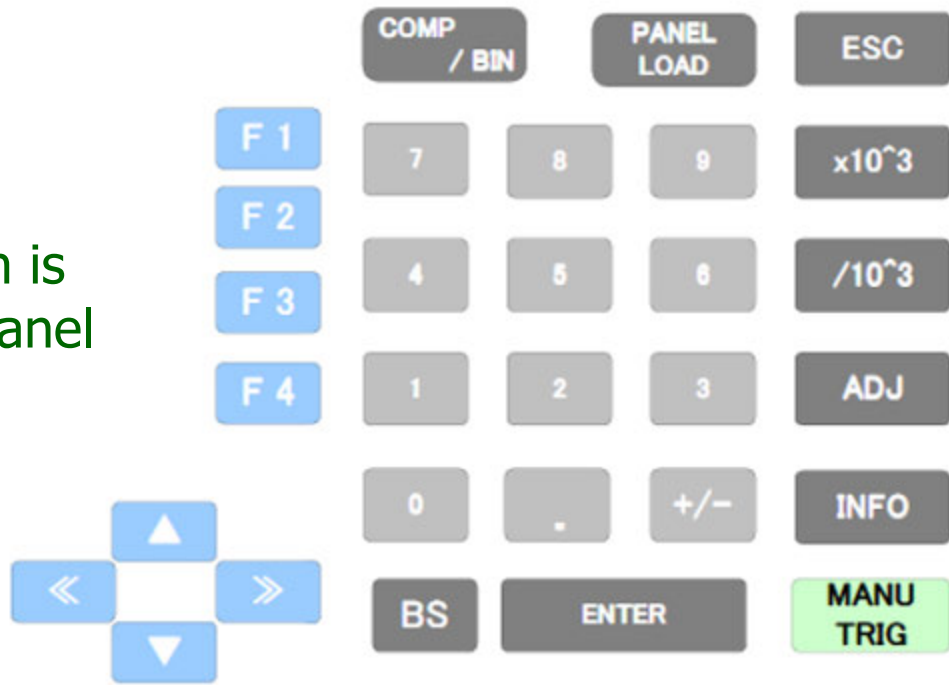

- Touch screen operation
- Range is automatically set according to the limit values
- Measurement conditions are independently set to each range



- Test speed: 2ms fastest (basic value)
- Shorter period for compensation
  - Faster OPEN/SHORT compensation
  - Range is automatically set according to the limit values

# OPEN/SHORT Compensation

Specify the frequency range to compensate  
Lower frequency = faster compensation

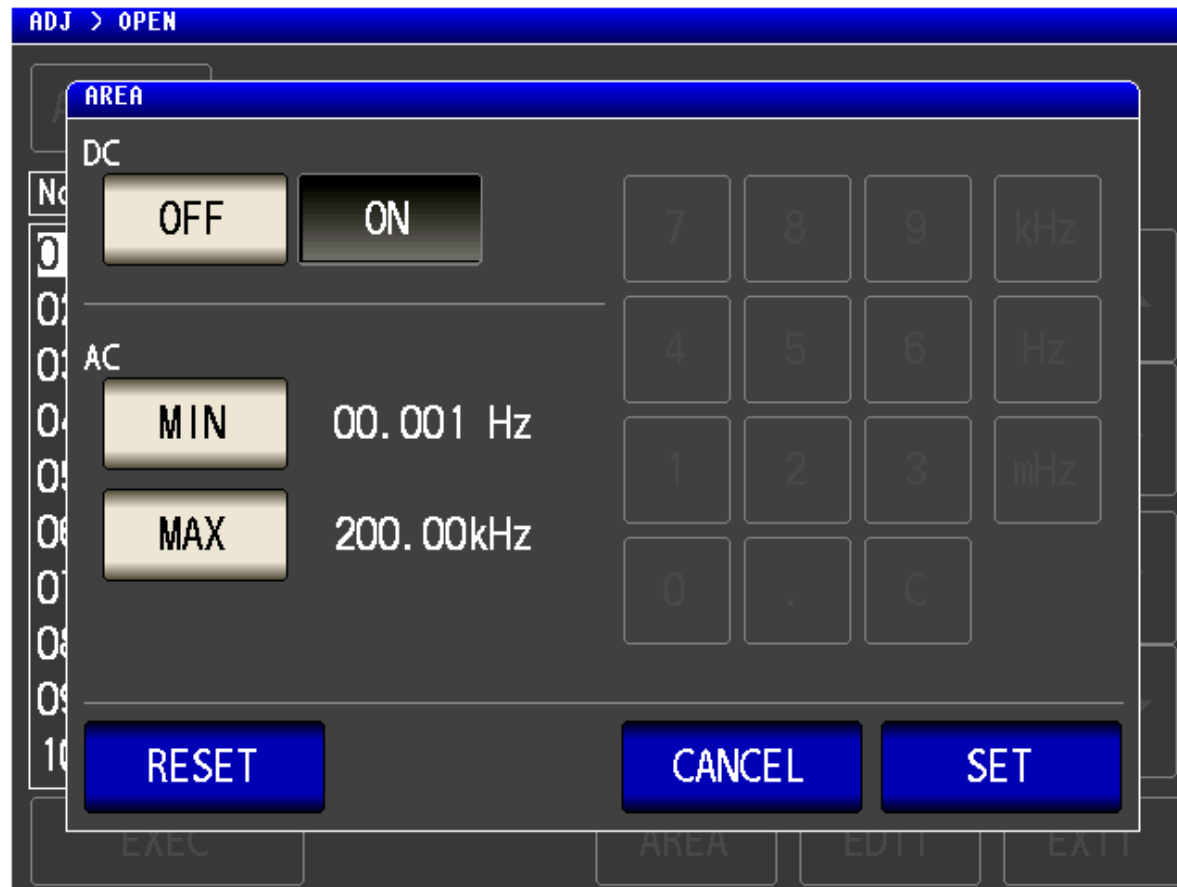

- Improved accuracy on ALL models

**+/-0.05%rdg.**

*(Z measurement)*

- Improved reliability using the contact check function
- More resistant against residual charge  
(when measuring after withstanding/insulation resistance test)



- 4-terminal measurement  
Check by contact resistance  
Contact resistance limit can be modified

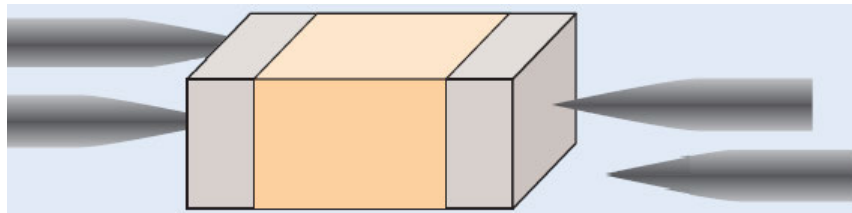

2-terminal measurement  
Hi-Z reject

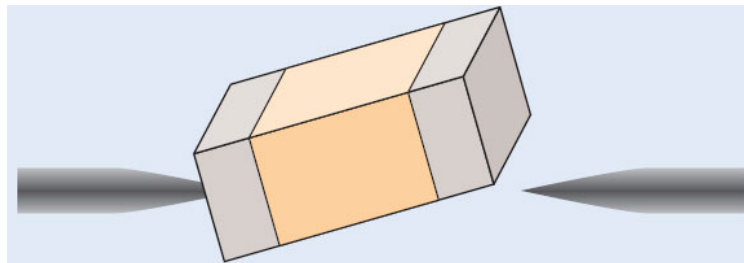

More resistant when measuring charged components

3532-50

$$V = \sqrt{(1/C)} \quad (400V \text{ max.})$$

Equivalent to 0.5J

IM3523, IM3533, IM3533-01

$$V = \sqrt{(10/C)} \quad (400V \text{ max.})$$

Equivalent to 5J

*However, discharging before measurement is still recommended.*

- Standard

- External I/O
- USB data port
- USB memory port (IM3533 and IM3533-01 only)

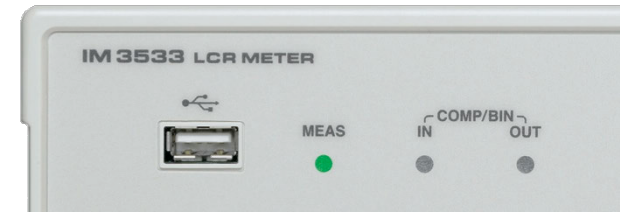

- Option (select one)

- RS-232C
- GP-IB
- LAN

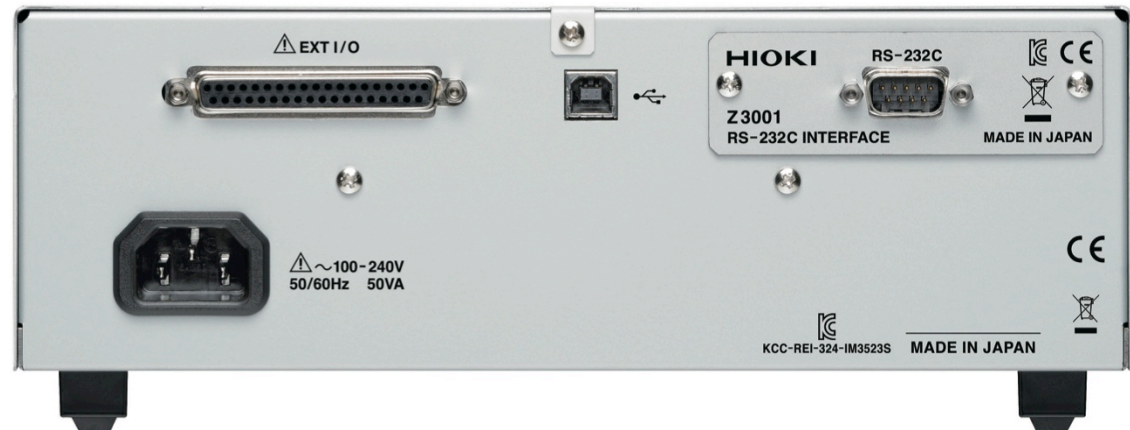

# Basic Specifications

Model		IM3523	IM3533	IM3533-01	3522-50
Measurement items	Z, Phase, Rs, Rp, Cs, Cp, Ls, Lp, Y, X, G, B, Q, D	Yes	Yes	Yes	Yes
	DCR	Yes	Yes (with temperature compensation)		Yes
	Transformer	---	N, M, Delta-L		---
	Temperature	---	Yes		---
Basic accuracy		0.05%rdg.			0.08%rdg.
Measurement frequency		40Hz to 200kHz	1mHz to 200kHz		1mHz to 100kHz
Test voltage (V/CV)		5mV to 5V	5mV to 5V/2.5V		10mV to 5V
Output impedance		100-ohm	100-ohm / 25-ohm (low Z range)		50-ohm
Fastest speed		2ms	2ms		5ms
Comparator		HI/IN/LO (ABS/%/Delta %) 2 items	HI/IN/LO (ABS/%/Delta %) 2 items		HI/IN/LO (ABS/%/Delta %) 2 items
BIN		Main item: 10 BINs Sub item: 1 BIN	Main item: 10 BINs Sub item: 10 BINs		---
Cable length compensation		0m/1m	0m/1m	0m/1m/2m/4m	0m/1m
Contact check		4-terminal check, Hi-Z reject	4-terminal check, Hi-Z reject		---
Built-in DC bias		---	-5V to 5V		---
Sweep measurement		---	---	Frequency sweep 2 to 801 points	---
Display		B/W LCD	Color 5.7-inch LCD, touch panel		B/W LCD, touch panel
Interfaces	Standard	EXT I/O	EXT I/O, USB, USB memory device		EXT I/O
	Option	RS-232C, GP-IB, LAN	RS-232C, GP-IB, LAN		RS-232C, GP-IB

- Different conditions can be tested by a SINGLE unit
- C-D measurement at 120Hz
- ESR measurement at 100kHz

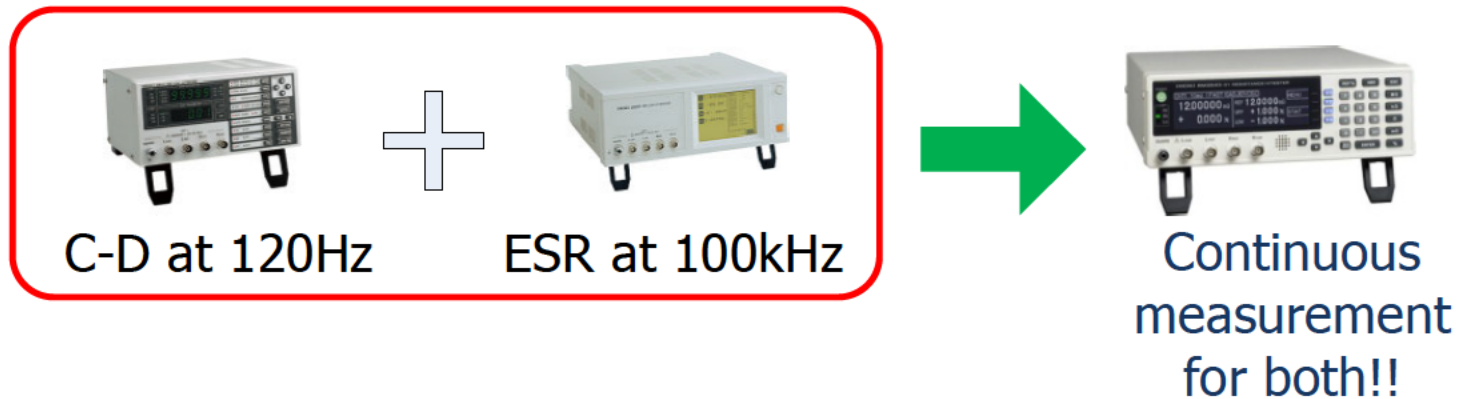

- DCR measurement
- L-Q measurement

- Independent comparator result output in continuous measurement

Previously: AND result only

New: Independent output  
(Can specify which is FAIL)

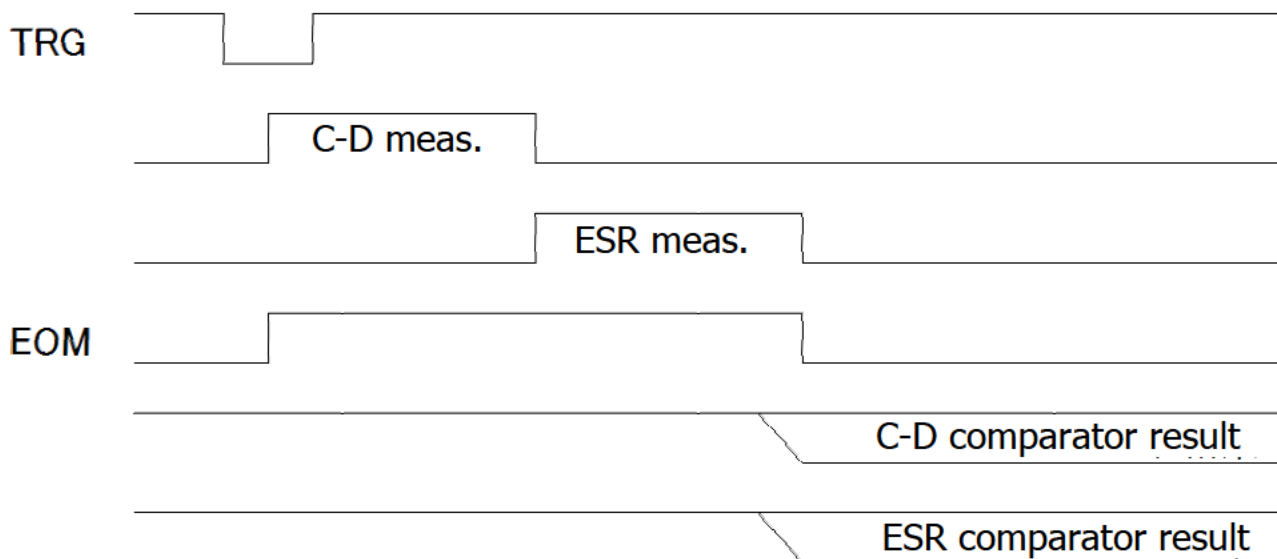

- Temperature compensation for DCR  
(IM3533 and IM3533-01 only)

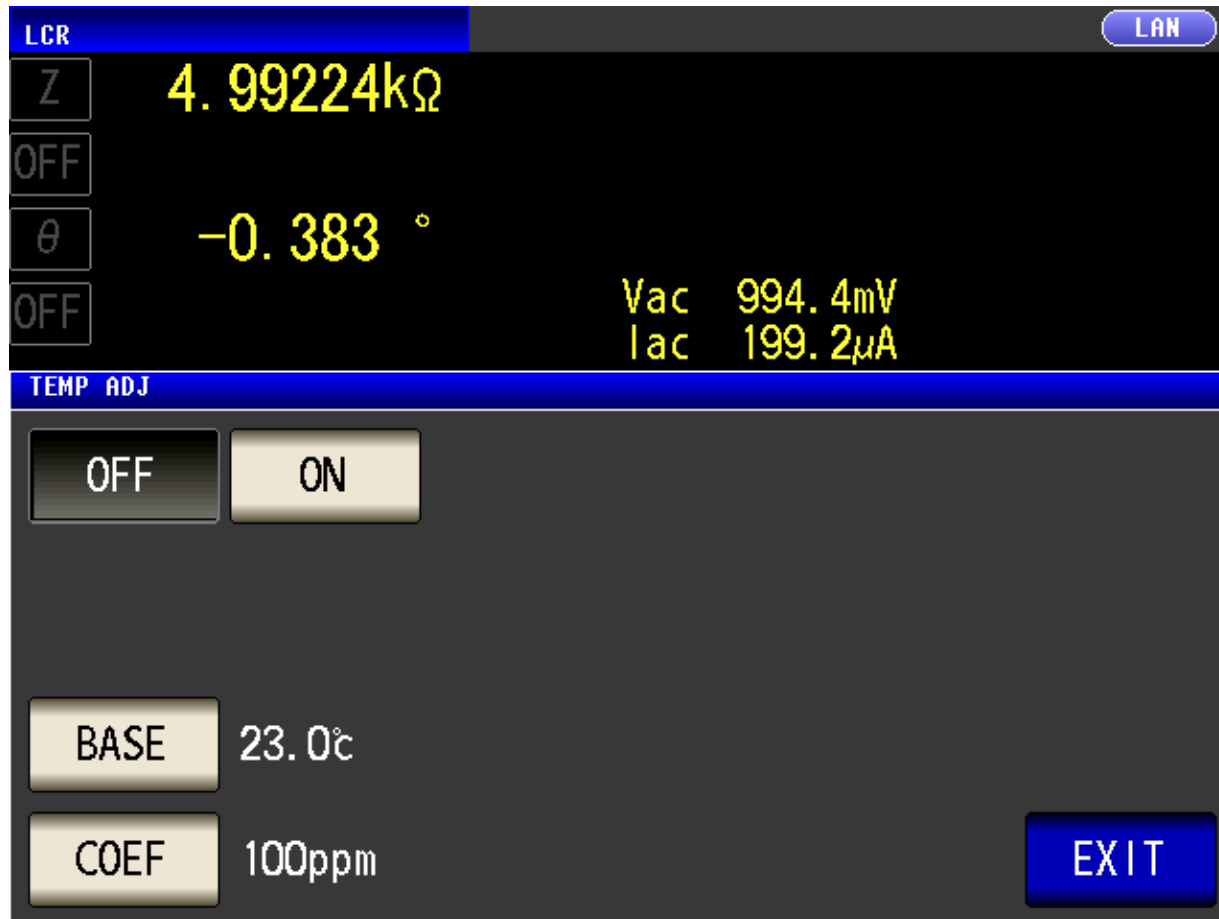

- TRANS mode: Transformer testing
  - N: Turn ratio
  - M: Mutual inductance
  - $\Delta L$ : Inductance difference

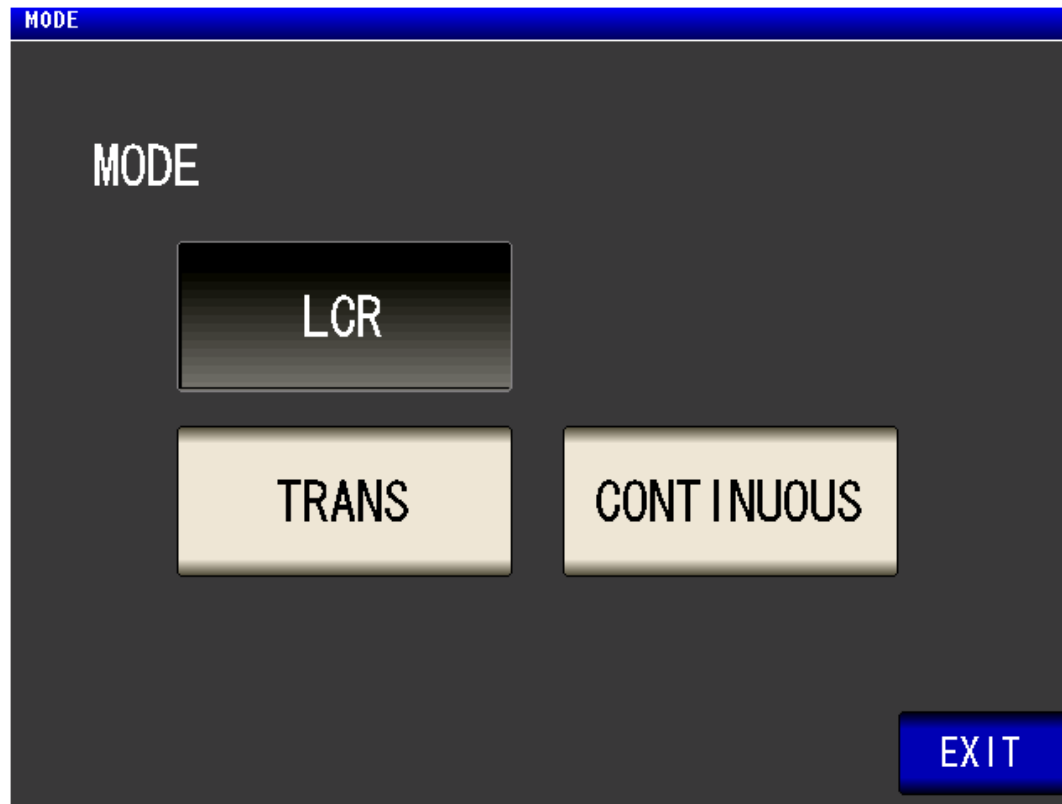



N: Turn ratio

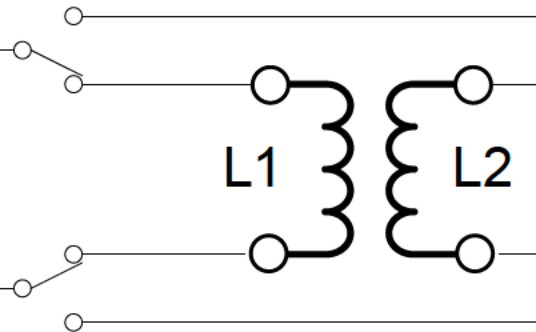

- (1) Measure L1 of primary
  - (2) Measure L2 of secondary
  - (3) Calculate N from L1 and L2
- $$N = \sqrt{L1/L2}$$

M: Mutual inductance

$\Delta L$ : Inductance difference

M: Relative inductance

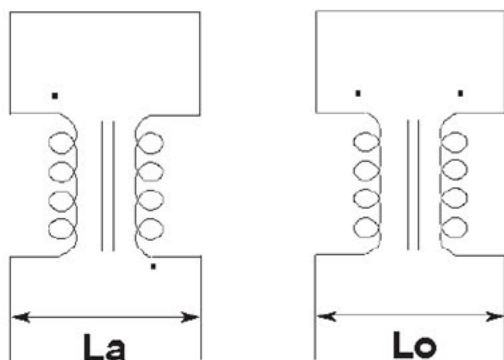

- (1) Measure  $L_a$  in-phase connection
- (2) Measure  $L_b$  in reverse-phase connection
- (3) Calculate  $M$  from  $L_a$  and  $L_b$

$$M = (L_a - L_b) / 4$$

$\Delta L$ : Inductance difference

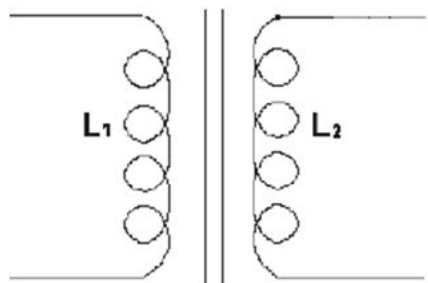

- (1) Measure  $L_1$  on primary
- (2) Measure  $L_2$  on secondary
- (3) Calculate  $\Delta L$  from  $L_1$  and  $L_2$

$$\Delta L = L_1 - L_2$$

- Different output impedance

**Important !!!**

	New Models	3522-50
Output impedance	100-ohm	50-ohm
Recommended cable impedance	50-ohm	75-ohm
Compatible Probes and Fixtures		
9140 4-terminal Probe	No	OK
9143 Pincher Probe	No	OK
9261 Test Fixture	No	OK
L2000 4-Terminal Probe	OK	No
9262 Test Fixture	OK	OK
9263 SMD Test Fixture	OK	OK
9677 SMD Test Fixture	OK	OK
9699 SMD Test Fixture	OK	OK

*The measurement result can differ depending on the cable impedance. Use the appropriate probes.*

- DC power supply and 9268-01 are no longer necessary using the built-in DC bias in Model IM3533

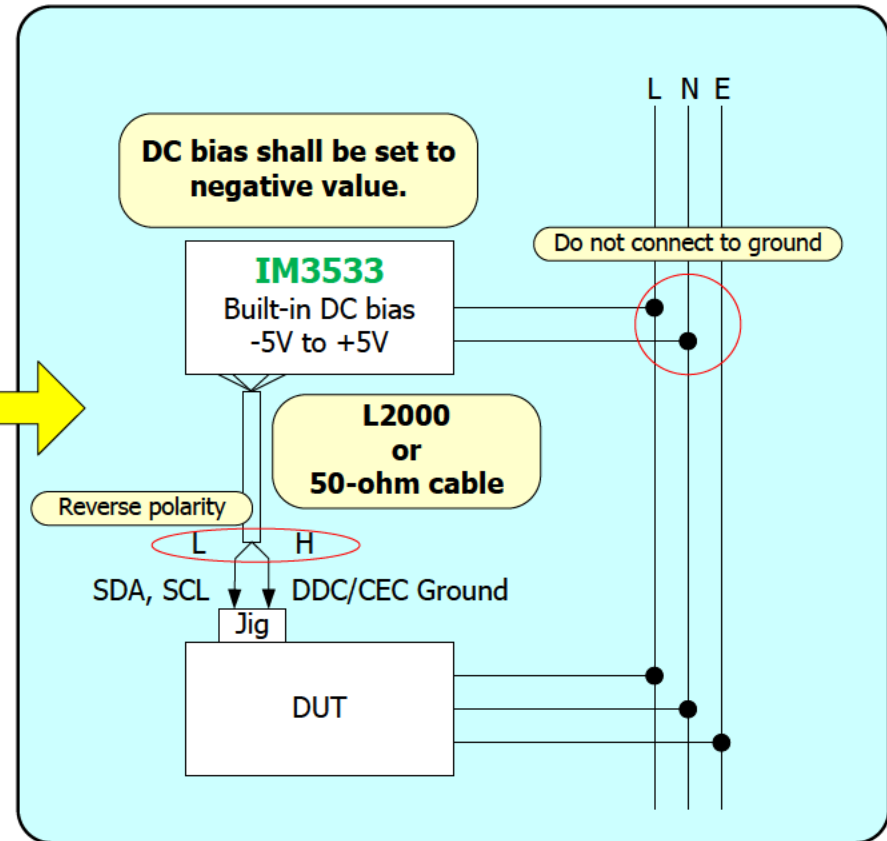
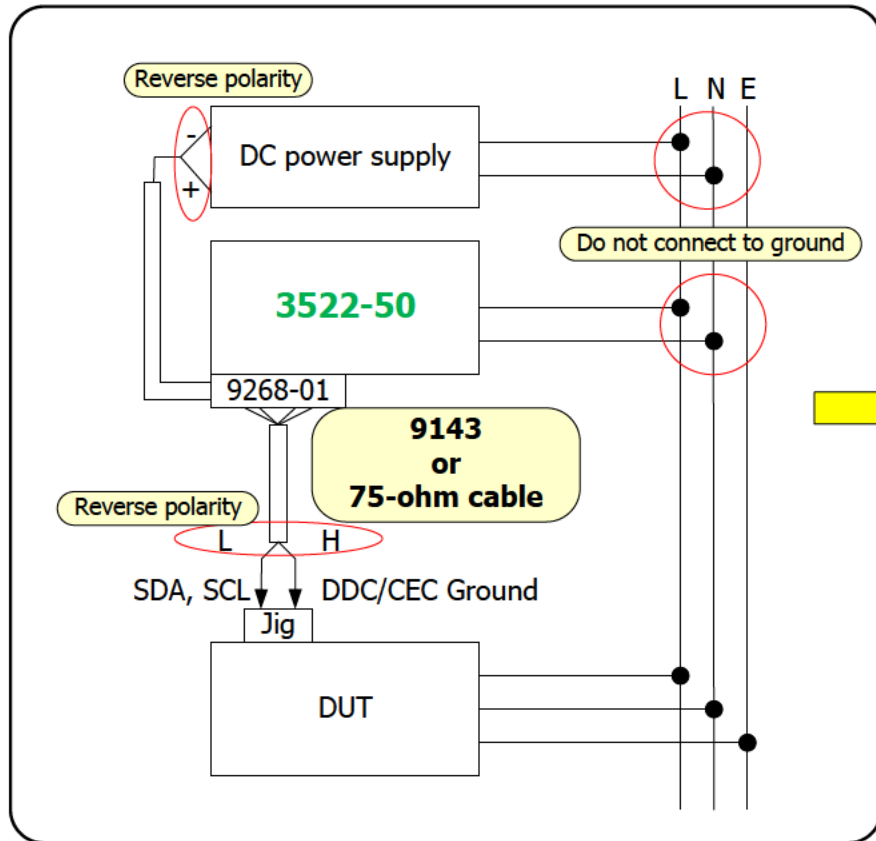

*Reverse the polarity if the measurement value is unstable.*

## IM3523, IM3533, IM3533-01 LCR Testers



HIOKI E. E. CORPORATION

[www.hioki.com](http://www.hioki.com)